

**Modular Cooking Range Line
 thermaline 90 - Electric Free-cooking
 Top on Warming Cabinet with
 Backsplash H=700**

ITEM # _____

MODEL # _____

NAME # _____

SIS # _____

AIA # _____



589708 (MCTHEBJ4AO) Electric Free-Cooking Top, one-side operated with backsplash, on Warming Cabinet

Short Form Specification

Item No. _____

Unit constructed according to DIN 18860_2 with 20 mm drop nose top. Internal frame for heavy duty sturdiness in stainless steel. 2 mm top in 1.4301 (AISI 304). Flat surface construction, easily cleanable. THERMODUL connection system enables seamless worktop when units are connected and avoids soil penetrating. Smooth electrically-heated solid plate made of 20 mm thick steel with a wide rounded cleaning zone around the plate. Rapid plate heat up, continuously ready to use; maximum reachable surface temperature of 350°C. Stainless steel high splash guards on the rear and sides. Overheat protection switches off the supply in case of overheating. Standby function saves energy and quickly recovers maximum power. Metal knobs with embedded hygienic silicon "soft" grip enable easier handling and cleaning. 1000 mm wide warming cabinet with 2 doors, constructed according to DIN 18860_2 with 70 mm recessed plinth. Temperature in the cabinet can be set through thermostat, up to a maximum of 110 °C. Cabinet storage space accepts GN 1/1 containers. IPX5 water resistance certification.

Main Features

- Rapid heat up of the plate and continuously ready for use.
- Overheat protection: the temperature sensor switches off the supply in case of overheating.
- Wide rounded cleaning zone around the plates for easier cleaning.
- All major components may be easily accessed from the front.
- THERMODUL connection system creates a seamless work top when units are connected to each other thus avoiding soil penetrating vital components and facilitating the removal of units in case of replacement or service.
- Metal knobs with embedded hygienic "soft-touch" grip for easier handling and cleaning. The special design of the controls prevents infiltration of liquids or soil into vital components.
- Large visible digital display manufactured in tempered glass to resist heat and chemicals, showing temperatures or power settings. The display also shows on/off status of the appliance and on/off status of the heating elements.
- Cooking plate and base joint profile guarantee against soil infiltration.
- Surface temperature up to 350°C
- Unit constructed according to DIN 18860_2 with 70 mm recessed plinth.
- For direct and indirect cooking.
- Temperature in the cupboard can be set through a thermostat to suit different requirements. The maximum temperature is 110°C.

Construction

- 2 mm top in 1.4301 (AISI 304).
- Unit constructed according to DIN 18860_2 with 20 mm drop nose top and 70 mm recessed plinth.
- Flat surface construction with minimal hidden areas to easily clean all surfaces
- IPX5 water resistance certification.
- Storage space in the base of the appliance accepts GN1/1 containers.
- Unit constructed according to DIN 18860_2 with 20 mm drop nose top.
- Cooking surface is an electrically heated solid plate made from 20 mm thick stainless steel AISI 316 - DIN 1.4404.
- 2mm thick top in stainless steel AISI 304 - DIN 1.4301.
- Internal frame for heavy duty sturdiness in stainless steel.

APPROVAL: _____



Sustainability

- Standby function for energy saving and fast recovery of maximum power.

Optional Accessories

- Connecting rail kit for appliances with backsplash, 900mm PNC 912499
- Portioning shelf, 1000mm width PNC 912528
- Portioning shelf, 1000mm width PNC 912558
- Folding shelf, 300x900mm PNC 912581
- Folding shelf, 400x900mm PNC 912582
- Fixed side shelf, 200x900mm PNC 912589
- Fixed side shelf, 300x900mm PNC 912590
- Fixed side shelf, 400x900mm PNC 912591
- Stainless steel front kicking strip, 1000mm width PNC 912636
- Stainless steel side kicking strips left and right, against the wall, 900mm width PNC 912660
- Stainless steel side kicking strip left and right, back-to-back, 1810mm width PNC 912663
- Stainless steel plinth, against wall, 1000mm width PNC 912941
- Stainless steel plinth, freestanding, 1000mm width PNC 912960
- Connecting rail kit for appliances with backsplash: modular 90 (on the left) to ProThermetic tilting (on the right), ProThermetic stationary (on the left) to ProThermetic tilting (on the right) PNC 912981
- Connecting rail kit for appliances with backsplash: modular 90 (on the right) to ProThermetic tilting (on the left), ProThermetic stationary (on the right) to ProThermetic tilting (on the left) PNC 912982
- Back panel, 1000x700mm, for units with backsplash PNC 913015
- Stainless steel panel, 900x700mm, against wall, left side PNC 913101
- Stainless steel panel, 900x700mm, against wall, right side PNC 913105
- Endrail kit, flush-fitting, with backsplash, left PNC 913117
- Endrail kit, flush-fitting, with backsplash, right PNC 913118
- Scraper for smooth plates PNC 913119
- Endrail kit (12.5mm) for thermaline 90 units with backsplash, left PNC 913208
- Endrail kit (12.5mm) for thermaline 90 units with backsplash, right PNC 913209
- U-clamping rail for back-to-back installations with backsplash (to be ordered as S-code) PNC 913226
- Insert profile d=900 PNC 913232
- Perforated shelf for warming cabinets and cupboard bases (one-side operated TL80-85-90 and two-side operated for TL80) PNC 913235
- Side reinforced panel only in combination with side shelf, for against the wall installations, left PNC 913267

- Side reinforced panel only in combination with side shelf, for against the wall installations, right PNC 913269
- Shelf fixation for TL80-85-90 one-side operated, TL80 two-side operated PNC 913283
- Filter W=1000mm PNC 913666
- Stainless steel dividing panel, 900x700mm, (it should only be used between Electrolux Professional thermaline Modular 90 and thermaline C90) PNC 913672
- Stainless steel side panel, 900x700mm, flush-fitting (it should only be used against the wall, against a niche and in between Electrolux Professional thermaline and ProThermetic appliances and external appliances - provided that these have at least the same dimensions) PNC 913688

Recommended Detergents

- C41 HI-TEMP RAPID DEGREASER, 1 pack of six 1 lt. bottles (trigger incl.) PNC 0S2292

Front

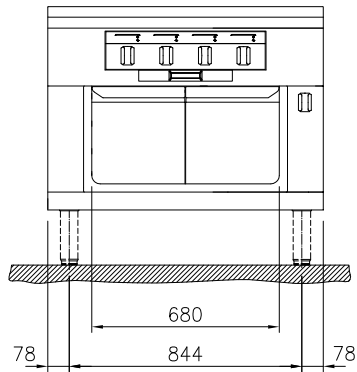

Side

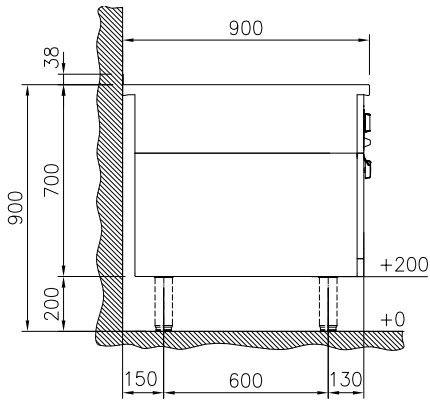

EI = Electrical inlet (power)
 EQ = Equipotential screw

Top

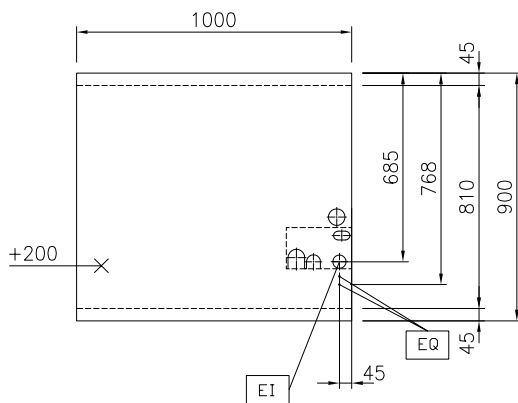

Electric

Supply voltage: 400 V/3N ph/50/60 Hz
Electrical power, max: 18.3 kW

Key Information:

Working Temperature MIN: 80 °C
Working Temperature MAX: 350 °C
External dimensions, Width: 1000 mm
External dimensions, Depth: 900 mm
External dimensions, Height: 700 mm
Storage Cavity Dimensions (width):
Storage Cavity Dimensions (height):
Storage Cavity Dimensions (depth): 0 mm
Net weight: 258 kg
Configuration: On Oven; One-Side Operated
Front Plates Power: 4 - 4 kW
Back Plates Power: 4 - 4 kW
Solid top usable surface (width): 820 mm
Solid top usable surface (depth): 720 mm

Sustainability

Current consumption: 39.1 Amps